



CEE Relays Ltd

87C Whitby Road, Slough, SL1 3DR (Registered Office)

Tel: (01753) 576477 Fax: (01753) 825661

Web: www.ceerelays.co.uk



TIME-LAG RELAYS

RAT SERIES

GENERAL MODEL

USER'S HANDBOOK

Foreword

The author disclaims all responsibility further to incorrect use of information or diagrams reproduced in this document, and cannot be held responsible for any errors or oversights, or for the consequences of using information and diagrams contained in this document.

CONTENTS

1	OBJECT	4
2	RANGE	4
3	OPERATING PRINCIPLES	4
4	RECEPTION & STORAGE	4
5	EXTERNAL CONNECTIONS DIAGRAM	5
5.1	Size PAV2 time-lag relays	5
5.2	Size PAV3 time-lag relays	6
6	FUNCTIONAL CHARACTERISTICS	7
6.1	Timing	7
6.2	Functions	9
6.3	Indicators on the relays	16
6.4	Changing the time or function settings	16
7	TECHNICAL CHARACTERISTICS	17
8	STANDARDS AND TESTS	18
8.1	Construction Standards	18
8.2	Electromagnetic Compatibility Tests	19
8.3	Vibration and shock stress tests	19
9	DIMENSIONS AND TYPES OF SOCKETS	20
9.1	Dimensions of the RAT2002	20
9.2	Dimensions of the RAT3044 and RAT3008	20
9.3	Sockets	21
10	APPENDIX 1. MODEL SELECTION TABLE	22

1 OBJECT

This manual is intended to help users to operate the RAT time-lag relays.

2 RANGE

The new range of time-lag relays comprises the following models:

- RAT2002: Time-lag relay with 2 timer contacts.
- RAT3044: Time-lag relay with 4 timer contacts and 4 instantaneous contacts.
- RAT3008: Time-lag relay with 8 timer contacts.

3 OPERATING PRINCIPLES

The new multifunction RAT relays, include multiple timing functions. Furthermore, these relays stand out by their wide range of timings, as well as by the simplicity of the operation. All the relay rated voltages work indistinctly both with direct or alternating current and the operation range is +25% / -30% of the nominal voltage (UN), except for 220 volts, which has a range of +10% / -20%.

4 RECEPTION & STORAGE

The RAT time-lag relays are supplied with packaging capable of protecting them during normal handling for equipment of this type.

If they are not to be installed immediately, they should be kept in the packaging, properly closed and in indoor conditions, protected from rain, dust, vibration, etc.

If the packaging is damaged or it is believed that the unit may have been incorrectly handled in transit, the carrier, the relevant insurance company and the manufacturing plant should be informed forthwith.

Check also that the data on the ID plate match the order data.

5 EXTERNAL CONNECTIONS DIAGRAM

5.1 PAV2 size time-lag relays

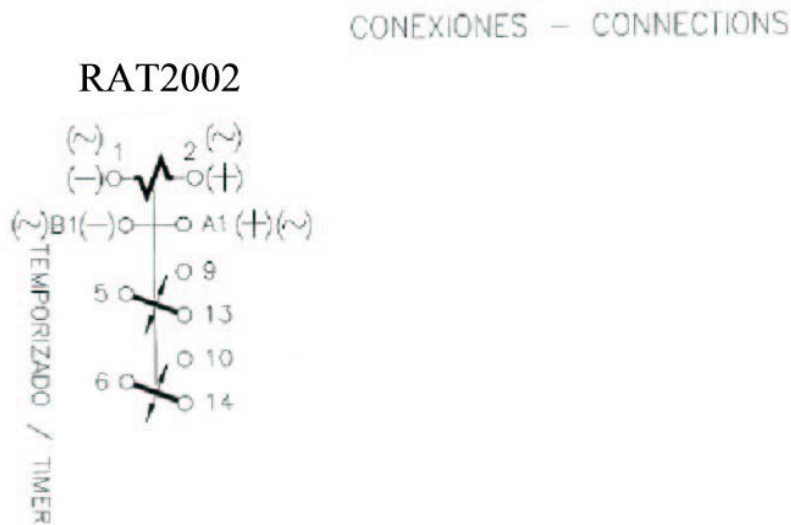

In an RAT2002:

- The terminals 2-1 are for the auxiliary supply of the relay.
- If the control is dependent, the negative of the same will be shared with the negative of the auxiliary supply (terminal 1) and the control signal will be B1. In the case of independent control the terminals 12-B1 will be the relay control signal or external control. The voltage for this signal is the same as for the auxiliary supply, with also identical operation range.
- The 5-9-13 and 6-10-14 are timer contacts.

5.2 PAV3 size time-lag relays.

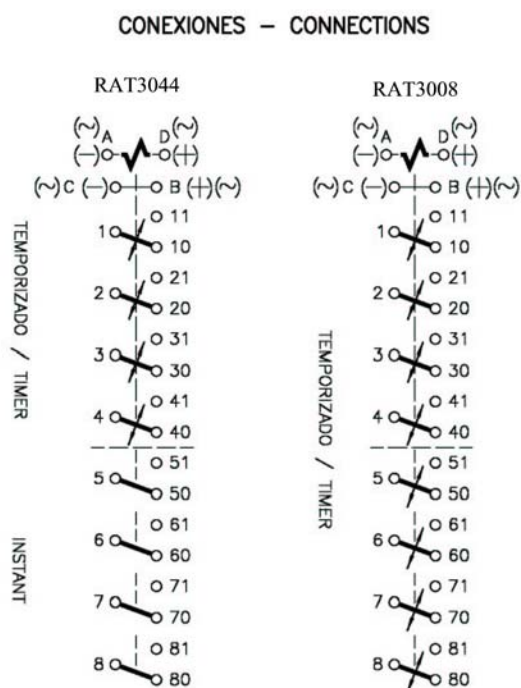

In an RAT3044:

- The terminals D-A are for the auxiliary supply of the relay.
- If the control is dependent, the negative of the same will be shared with the negative of the auxiliary supply (terminal A) and the control signal will be B. In the case of independent control the terminals B-C will be the relay control signal or external control.
- The 4-40-41, 3-30-31, 2-20-21 and 1-10-11 are timer contacts.
- The contacts 8-80-81, 7-70-71, 6-60-61 and 5-50-51 are instantaneous (operating time lower than 20 ms).

In an RAT3008:

- The terminals D-A are for the auxiliary supply of the relay.
- If the control is dependent, the negative of the same will be shared with the negative of the auxiliary supply (terminal A) and the control signal will be B. In the case of independent control the terminals B-C will be the relay control signal or external control.
- All the other contacts are timer contacts.

6 FUNCTIONAL CHARACTERISTICS

6.1 Timing

To choose the desired timing, the relays have 3 selectors available on the front part: in each of them the position of the point of the arrow indicates the option number selected. All the selectors are of discreet step not continuous, and for this reason the arrow cannot stay in an intermediate position.

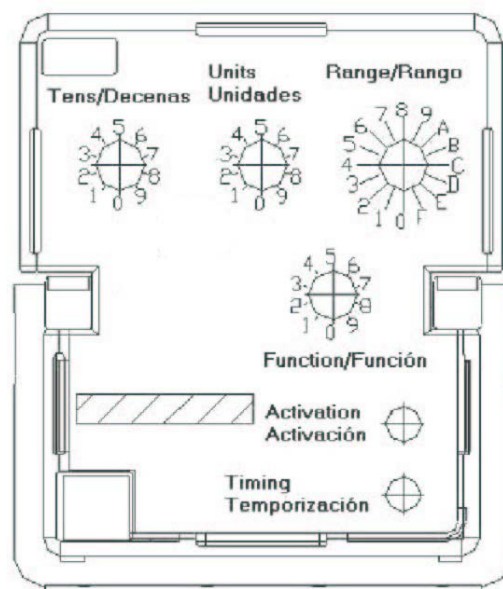

The 16-position selector with the indication “Range”, on top right part, allows users to choose between the different 16 time ranges available. Each of the ranges is determined by a low limit and a top limit, as well as, by a step, as it is shown in the following table. This same table is printed on the left side of the relay.

Range	Low limit	Top limit	Step
0	0.03s	990ms	10ms
1	0.03s	2.97s	30ms
2	0.1s	9.9s	100ms
3	0.2s	19.8s	200ms
4	0.5s	49.5s	0.5s
5	1s	99s	1s
6	3s	297s	3s
7	5s	495s	5s

Range	Low limit	Top limit	Step
8	10s	990s	10s
9	0.5min	49.5min	0.5min
A	1min	99min	1min
B	3min	297min	3min
C	5min	495min	5min
D	10min	990min	10min
E	0.5h	49.5h	0.5h
F	1h	99h	1h

On the following example, the chosen range would be the 5, which low limit is 1 second and the top is 99 seconds, with a step of 1 second.

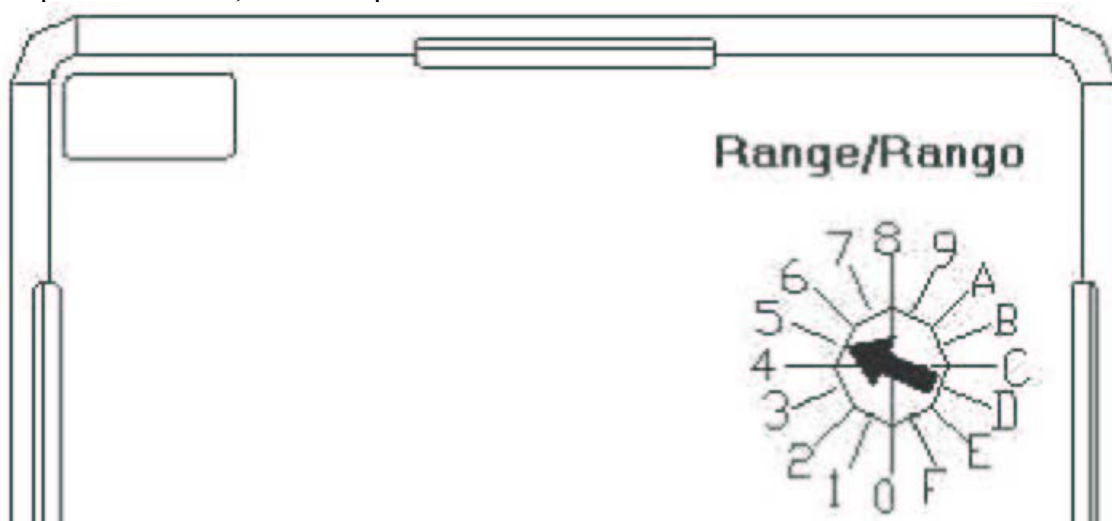

The combination of the two 10 position selectors, placed on the left side of the “Range” selector, allows users to select a number between 1 and 99. The number selected on the selector “Tens” multiplied by 10, plus the number selected on the selector “Unit” will be the chosen number. Once the range is selected, this number is the times that the step is going to be multiplied, in order to choose this way the time on which the relay will operate.

This way, on the following example:

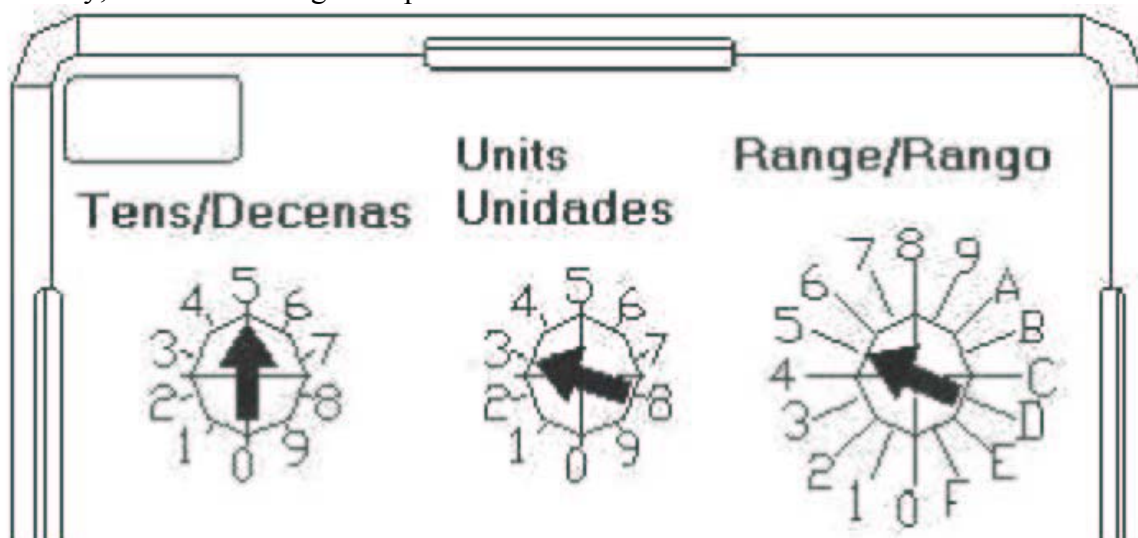

The range that has been chosen is the 5, which step is 1 second. As the tens selector is on the position 5 ($5 \times 10 = 50$) and the unit one is on the 3 ($50 + 3 = 53$), the relay will temporize 53 times the step, in other words, it will temporize $53 \times 1 = 53$ seconds.

NOTE 1: If the tens selector is placed on the 0 and the unit one on the 0 or on the 1, the relay temporizes the step of the selected range.

NOTE 2: As the relay cannot temporize less than 30 milliseconds, if by the selectors it is chosen an option that would suppose a timing lower than this value, the relay will temporize 30ms. For example, if it is selected the range 0, tens 0, and units 1 or 2, according to what was mentioned on the preceding page, the timing would be 10 ms or 20 ms respectively, but the relay will temporize 30 ms as it is the minimum timing limit.

On the rest of the positions the timing will be the selected value.

NOTE 3: If all the selectors are placed on 0 (Tens 0, Units 0, Range 0 and Function 0), the timing will be disabled and the relay will operate in the minimum time possible (electronic and mechanical initialization delay). This time is a bit lower than 20ms. In a relay with an instantaneous coil, both coils the instantaneous and the time lag will operate at the same time.

NOTE 4: The accuracy of the timing will be $\pm 5\text{ms}$ or $\pm 1\%$ (whichever is greater).

6.2 Functions

Below the 3 timing selectors, there is a fourth 10-position selector, which allows users to choose the different functions that the relay can execute. The way to make the selection is the same as ones explained before, by the point of the arrow.

On the figure shown below, the selected function would be the 6.

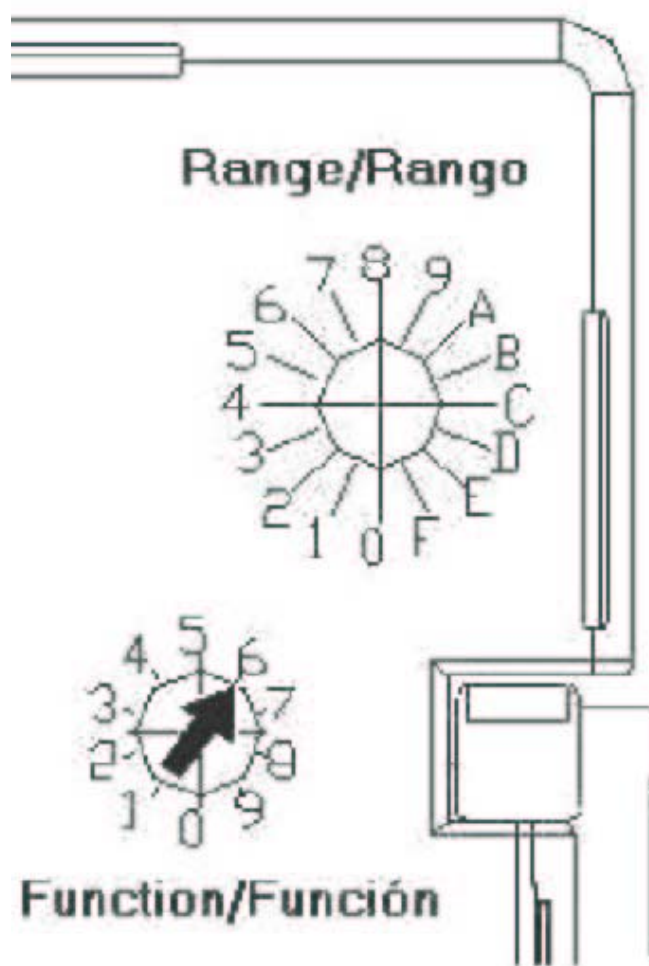

The time diagrams for each of the functions available are printed on the right side of the relay. The description, as well as the mentioned diagrams for each of these functions is, shown below. All the descriptions and the time diagrams are referred to the RAT2004 and the RAT2022 but the explanations are extensive to the RAT3008 and the RAT3044. The only difference is the number of timer and instantaneous contacts.

First, the following table summarises all the functions available with a short description of each one:

Function 0	Pick up timing.
Function 1	Pick up timing with acceleration by external control.
Function 2	Drop out timing, the instantaneous part of the RAT2022 follow the auxiliary supply.
Function 3	Drop out timing, the instantaneous part of the RAT2022 follow the external control.
Function 4	Timing with continuity control.
Function 5	Permanent cycle timing.
Function 6	Flashing timing.
Function 7	Pick up timing.
Function 8	Drop out timing.
Function 9	Pick up timing with reduced resetting time.

FUNCTIONS 0 & 9 (pick up timing):

As soon as the relay is with auxiliary supply, the timing starts, and the contacts pick up (go from the resting position to the working position) after a period of time t has passed (selected time).

In the RAT2004 and RAT3008, all their contacts operate this way. In the RAT2022 (that is the relay to which belongs the following time diagram) and RAT3044, the timer contacts operate as it is indicated on the described function, while the instantaneous contacts will stay picked up every time the relay has auxiliary supply (the contacts follow the auxiliary supply).

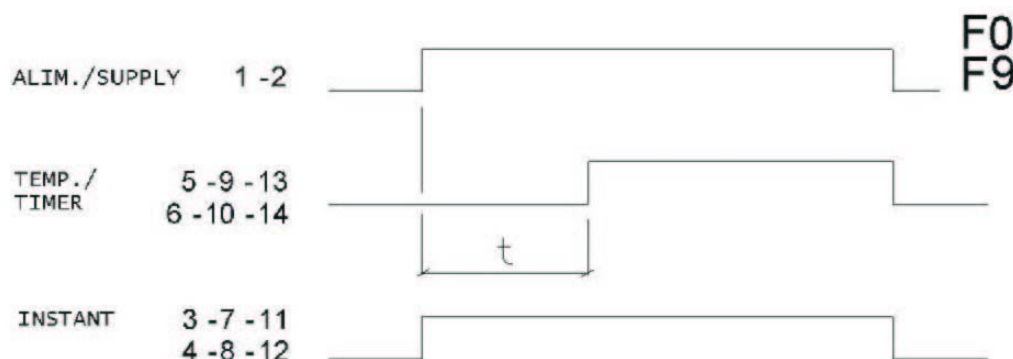

The only difference between functions F0 and F9 is the time the relay resets, (becomes operative again), after a loss of auxiliary supply.

In the function F0, as in the rest of the functions except F9, this time is guaranteed to be less than 200 milliseconds, being at the same time, higher than 100 milliseconds (because this 100 milliseconds is the voltage gap guaranteed).

In the function F9, this time is 40 milliseconds during timing and 20 ms if timing is finished.

NOTE: The period of time mentioned above is the one the relay takes in reset itself (start working as if it has been connected with auxiliary supply for the first time). If the relay loses the auxiliary supply for a lower period of time, the contacts drop out (the mechanics detect the loss) but the timing goes on as if there has not been any loss (the electronics do not detect the loss).

FUNCTION 1 (pick up timing with acceleration by external control):

This function differs from the function F0, in that there is an external control, that when the signal appears, the contacts pick up (go from the resting position to the working position), regardless of the timing that has been selected.

In other words, as soon as the relay is with auxiliary supply, if there is no control signal, the contacts pick up in the period of time selected t ; whereas if the control signal appears (which must last more than 10 ms) the contacts pick up, without waiting for this selected period of time to go by (as it is shown in the time diagram).

In the RAT2004 and RAT3008, all the contacts operate this way. In the RAT2022 (that is the relay to which belongs the following time diagram) and RAT3044, the timer contacts operate as it is indicated on the described function, while the instantaneous contacts will stay picked up every time the relay has auxiliary supply (the contacts follow the auxiliary supply).

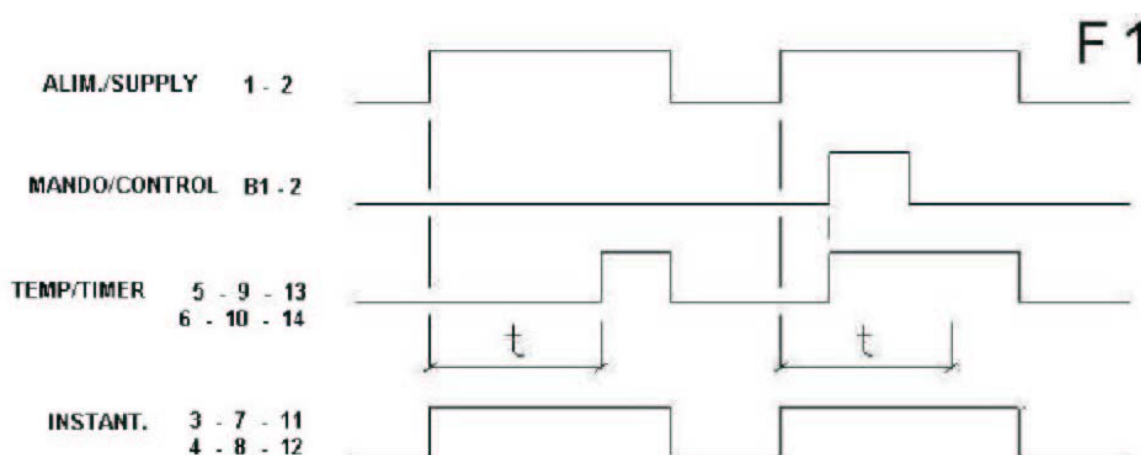
**FUNCTION 2 (drop out timing):**

If the relay is with auxiliary supply and the control signal appears (must last more than 10 ms) the contacts pick up (go from the resting position to the working position); once the control signal disappears, the selected period of time starts to count, after which the contacts drop out (go from the working position to the resting position). In case the control signal disappears and appears again after a period of time t' lower than the time t , the relay clock resets and goes to zero, restarting the time counting. Once the control signal disappears, the contacts continue to be in the working position until the selected period of time t has passed, moment in which the contacts drop out

In the RAT2004 and RAT3008, all the contacts operate this way. In the RAT2022 (that is the relay to which belongs the following time diagram) and RAT3044, the timer contacts operate as it is indicated on the described function, while the instantaneous contacts will stay picked up every time the relay has auxiliary supply (the contacts follow the auxiliary supply).

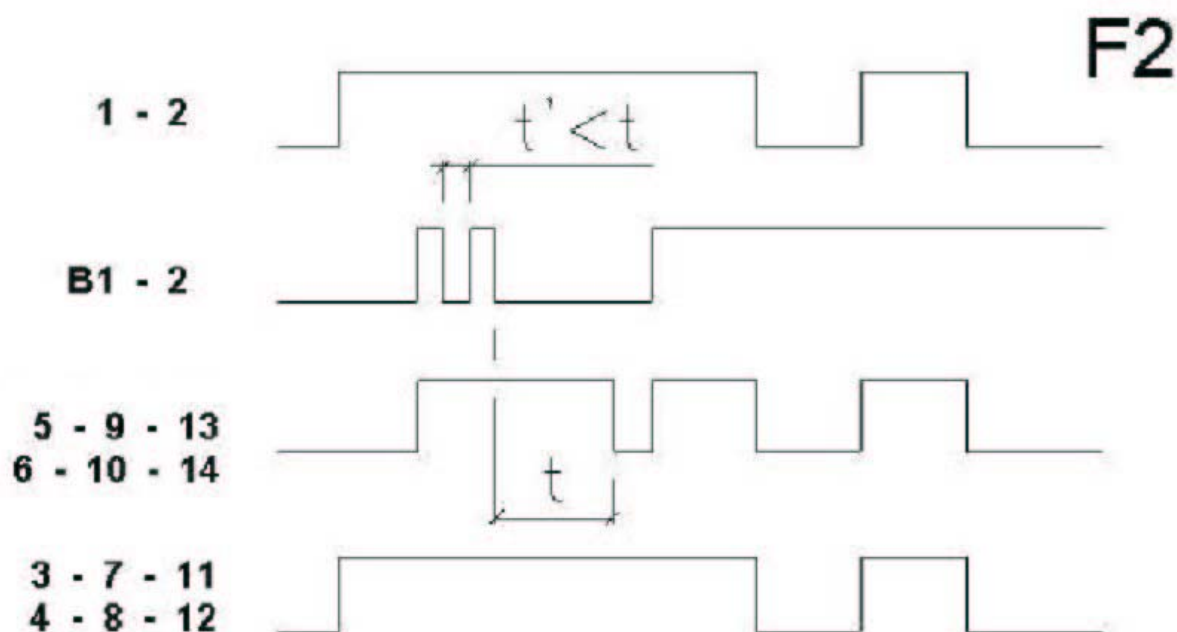
**FUNCTION 3 (drop out timing):**

Identical to function 2 in the RAT2004 and RAT3008. In the RAT2022 and RAT3044 the difference is that the instantaneous contacts stay picked up while the control signal exists (provided that the relay has auxiliary supply), in other words, the contacts follow the control, not the auxiliary supply as in the preceding function.

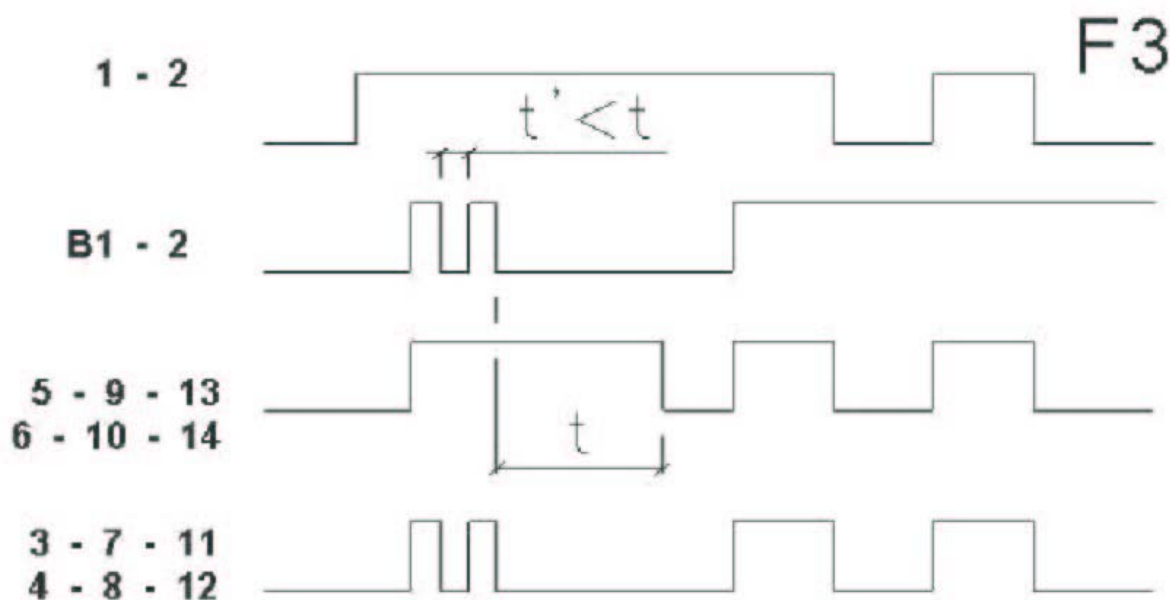
**FUNCTION 4 (timing with continuity control):**

When the relay has auxiliary supply, the time t (selected period of time) starts to count, after which the contacts pick up (go from the resting position to the working position). If there is no control signal, the contacts stay this way every time the relay has auxiliary supply.

The moment the control signal appears (must last more than 10 ms) the contacts drop out (go from the working position to the resting position). Just after the control signal disappears, the period of time t starts to count, after which the contacts return to the working position. The resting position will be recovered as soon as the control signal appears again. In the RAT2004 and RAT3008, all the contacts operate this way. In the RAT2022 (that is the relay to which belongs the following time diagram) and RAT3044, the timer contacts operate as it is indicated on the described function, while the instantaneous contacts will stay picked up every time the relay has auxiliary supply (the contacts follow the auxiliary supply).

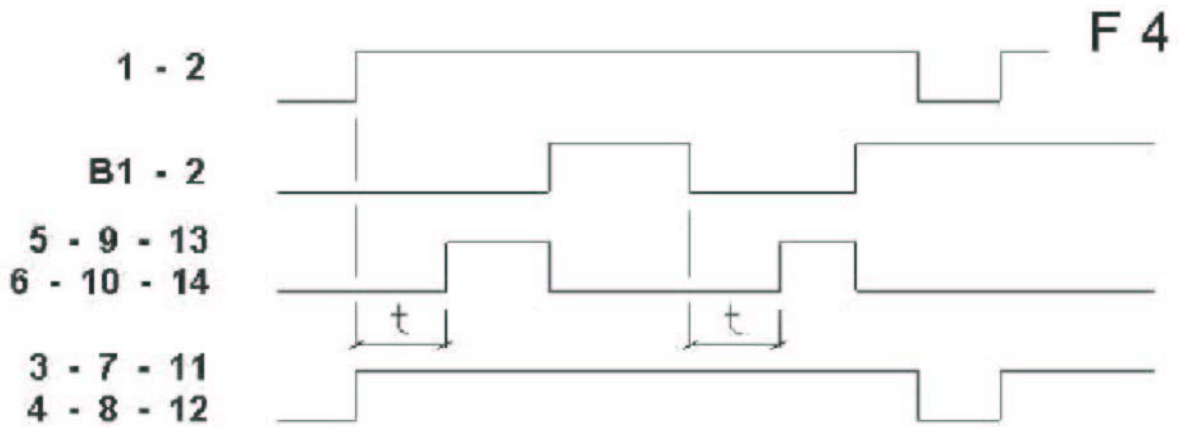

FUNCTION 5 (permanent cycle timing):

As soon as the relay has auxiliary supply a timing cycle begins, in which the contacts are 12 hours dropped out and 2 seconds picked up. This process lasts while the relay has auxiliary supply.

In the RAT2004 and RAT3008, all the contacts operate this way. In the RAT2022 (that is the relay to which belongs the following time diagram) and RAT3044, the timer contacts operate as it is indicated on the described function, while the instantaneous contacts will stay picked up every time the relay has auxiliary supply (the contacts follow the auxiliary supply).

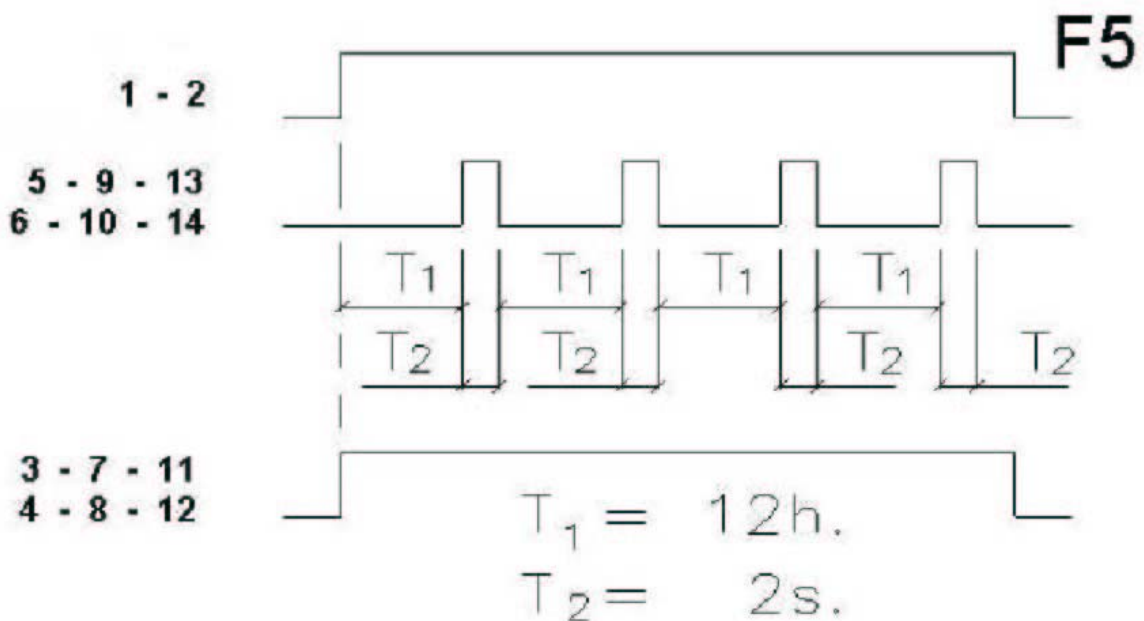

FUNCTION 6 (flashing timing):

As soon as the relay has auxiliary supply the timing begins, and after the selected period of time T the contacts pick up (go from the resting position to the working position) and remain in that position for the same period of time. After this time, the contacts drop out (go from the working position to the resting position) and remain in this position for the time T and so on, until the auxiliary supply disappears.

This process changes in case the control signal appears (it must last longer than 10 ms). If this happens, while the control signal exists the contacts remain picked up. Once this signal disappears, the contacts stay in the working position for the period of time T, and afterwards start again with the timing cycles as explained above.

In the RAT2004 and RAT3008, all the contacts operate this way. In the RAT2022 (that is the relay to which belongs the following time diagram) and RAT3044, the timer contacts operate as it is indicated on the described function, while the instantaneous contacts remain picked up while the control signal exists (provided that the relay has auxiliary supply), in other words, the contacts follow the control.

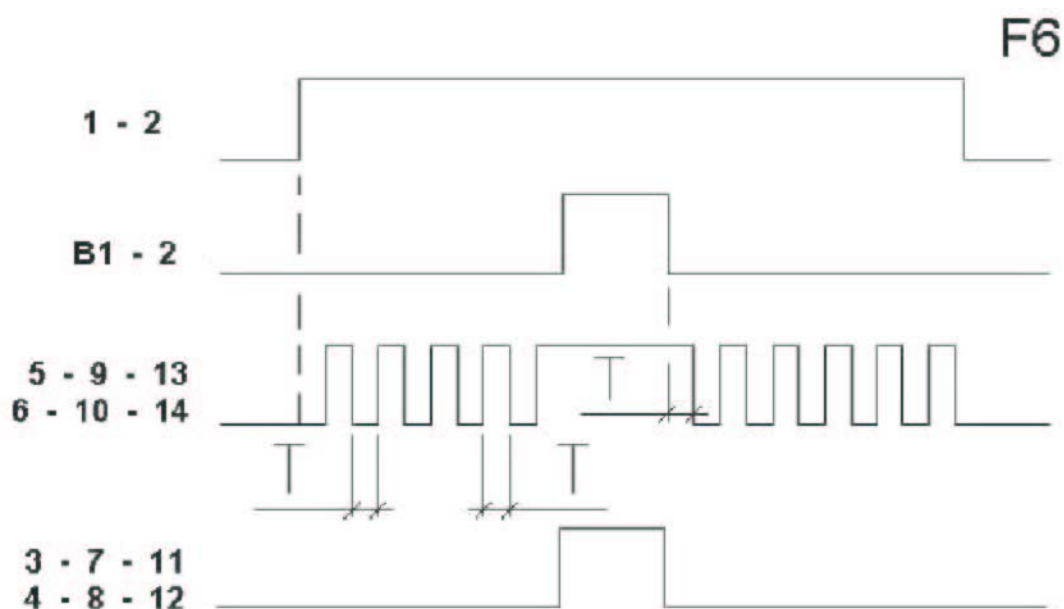
**FUNCTION 7 (pick up timing):**

If the relay is with auxiliary supply and the control signal appears (must last longer than 10 ms), the contacts pick up (go from the resting position to the working position) and remain in that position for a period of time t.

The time starts running once the control signal appears. If it disappears and returns again before it has passed the time t, does not affect to the counting. The time starts to count when the control appears, and only the first time for each timing.

In the RAT2004 and RAT3008, all the contacts operate this way. In the RAT2022 (that is the relay to which belongs the following time diagram) and RAT3044, the timer contacts operate as it is indicated on the described function, while the instantaneous contacts remain picked up while the control signal exists (provided that the relay has auxiliary supply), in other words, the contacts follow the control.

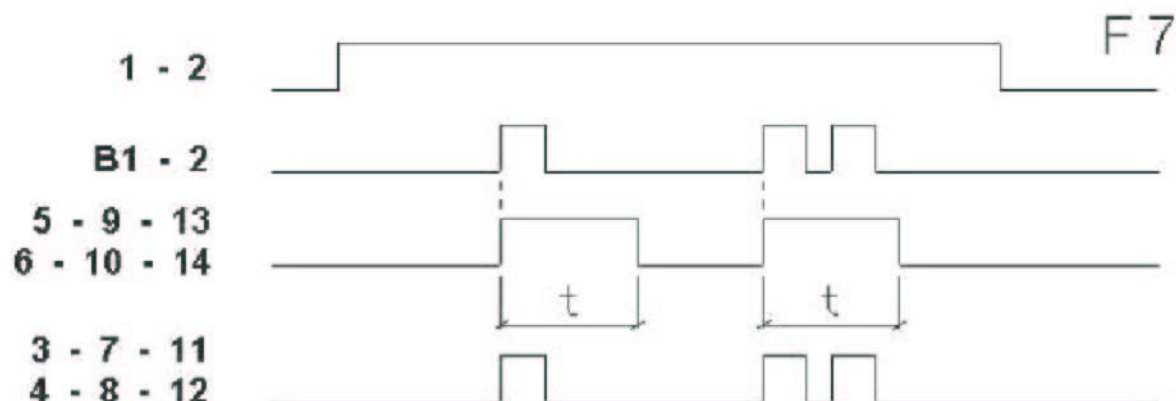

FUNCTION 8 (drop out timing):

If the relay is with auxiliary supply and the control signal appears and disappears (must last longer than 10 ms), the contacts pick up (go from the resting position to the working position) and remain in that position for a period of time t .

The time starts running once the control signal disappears. If it returns and goes away before it has passed the time t , does not affect to the counting. The time starts to count from the disappearance of the control and only the first time for each timing.

In the RAT2004 and RAT3008, all the contacts operate this way. In the RAT2022 (that is the relay to which belongs the following time diagram) and RAT3044, the timer contacts operate as it is indicated on the described function, while the instantaneous contacts remain picked up while the control signal exists (provided that the relay has auxiliary supply), in other words, the contacts follow the control.

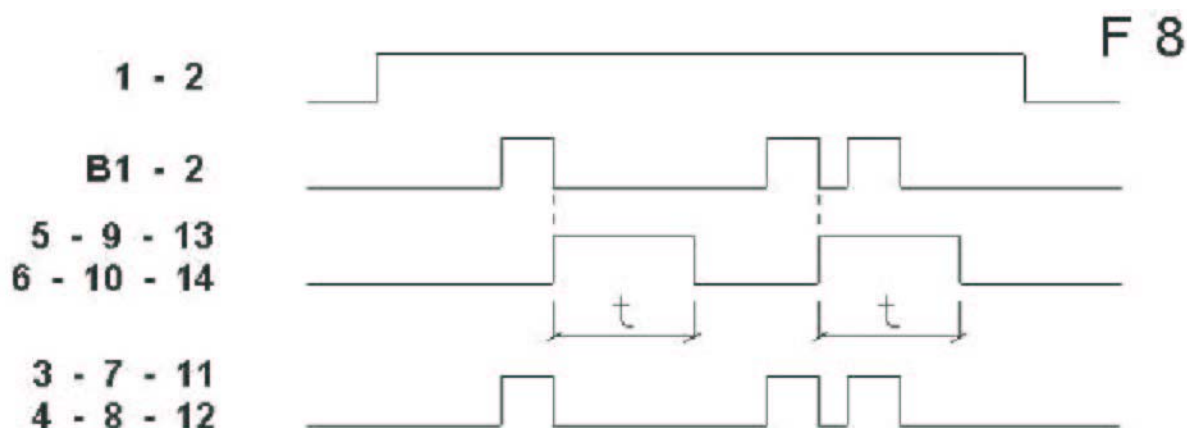

6.3 Indicators on the relays

There are 2 LEDs on the front part of the relay:

- **Activation LED:** it is a green led that is illuminated permanently when the timer contacts are picked up.
- **Timing LED:** it is a red led that flashes intermittently while the timing is in process in the relay, and turns off once the timing has finished.

6.4 Changing the time or function settings

In case the time or function selectors are changed, two situations may happen:

- *The changes are made in the relay without the auxiliary supply:* in this case, the changes in the settings, both in the timing and in the function, will be applied the next time the relay has auxiliary supply.
- *The changes are made while the relay has auxiliary supply:* in this case, the modifications will not be applied until the relay completely loses the auxiliary supply and is restored again. The loss of the auxiliary supply must be longer than 1s. In other words, it is necessary to disconnect the auxiliary supply of the relay for at least 1 second to make effective any change of time or timing function.

7 TECHNICAL CHARACTERISTICS

- Standard voltages (UN):
24,48,72,96,110,125,220 Vdc/Vac: 50/60 Hz
(Vdc/Vac voltage supply available in the same relay)
- Voltage operation range: +25% -30% UN (except for 220V).
- Consumption (UN):
RAT2002: $\leq 3.16\text{W}$
RAT3044: $\leq 8.81\text{W}$
RAT3008: $\leq 6.89\text{W}$

- Contacts:
Permanent current: 10A
Instantaneous current: 30A/1s; 80A/200ms; 150A/10ms
Making capacity: 40A/0.5s/110Vdc
Breaking capacity for 105 operations:
1.2A; 110Vdc; 0ms
0.8A; 110Vdc; 20ms
0.5A; 220Vdc; 0ms
0.3A; 220Vdc; 20ms
- Umax, opened contact: 250Vdc/400Vac
- Mechanical life: 10^7 operations
- Operating temperature: -10°C to $+55^{\circ}\text{C}$
- Operating humidity: 93%/40°C
- Seismic characteristics according to IEEE501
Degree of ZPA: 3 g/33 Hz

8 STANDARDS AND TESTS

8.1 Construction Standards

• Electrical test	IEC 60255-5
Dielectric test	2kV/50Hz/1min
Surge withstand	5 kV/1.2/50µs
Insulation	>2000MΩ/500Vdc
• Inflammability tests	IEC60692-2-1
Plastic materials	UL94: V0
	IEC 60695: 850°C/30 s
• Cover protection degree	IEC60529, EN60529: IP40
• Climatic tests	IEC60255-7
Dry heat	IEC60068-2-2
- Non-dissipating sample	+70°C/96 h
- Dissipating sample	+55°C/96 h
Cyclic humid heat	IEC60068-2-30: +55°C/12 h
Cold 100 cycles	IEC60068-2-1
Non-dissipating sample	-10°C/2h
Thermal aging test	IEC60255-7
At nominal voltage (UN)	+55°C/1440 h

8.2 Electromagnetic Compatibility Tests

- Electrostatic discharge (level 3)
 - Air mode EN61000-4-2, IEC61000-4-2
± 8kV
 - Contact mode ± 6kV
- Radiated electromagnetic field (level 3) EN61000-4-3, IEC61000-4-3
10V/m
- Fast transient (burst) (level 4) EN61000-4-4, IEC61000-4-4
 - Aux. Supply ±4kV/5kHz
 - Inputs ±4kV/5kHz
- Impulse test voltage (surge) (level 3) EN61000-4-5, IEC61000-4-5
 - Common mode ±2kV
 - Differential mode ±1kV
- Conducted disturbances induced by radio frequency fields (level 5) EN61000-4-6, IEC61000-4-6
10V
- Power frequency magnetic field (level 5) EN61000-4-8, IEC61000-4-8
 - Permanent 100A/m
 - During 1s 1,000A/m
- Damped oscillatory magnetic field EN61000-4-10, IEC61000-4-10
1 MHz and 0,1 MHz (level 5) 100A/m
- Oscillatory waves 1 MHz and 0,1 MHz (level 3) EN61000-4-12
100A/m
 - Common mode 2.5kV
 - Differential mode 1kV

8.3 Vibration and shock stress tests

- Railway applications. Rolling stock equipment. IEC 613736
Vibration and shock test:
 - Test Level Category 1, Class B
- Requirements for vibration and shock testing RIA 20
of equipment intended for use on railway vehicles:
 - Test Level Category 1, Class B
- Recommended Practice for Seismic Qualification IEEE 344
of Class 1E Equipment for Nuclear Power Generating Stations
Test Level:
 - ZPA = 3 with sockets mounted on Rail DIN
 - ZPA = 3,5 with screwed socket

9 DIMENSIONS AND TYPES OF SOCKETS

9.1 Dimensions of the RAT2002

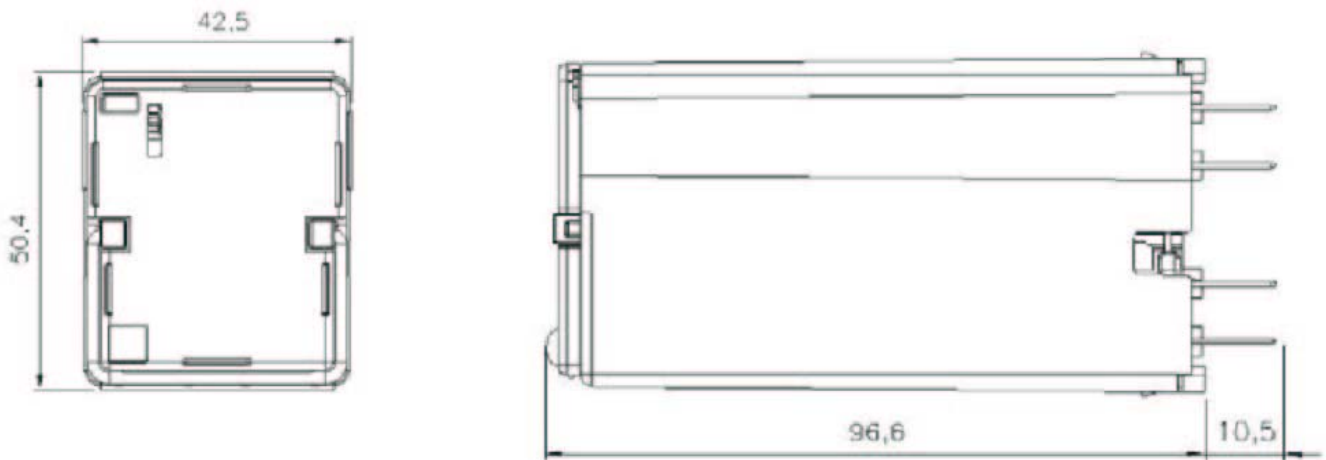

9.2 Dimensions of the RAT3044 and RAT3008

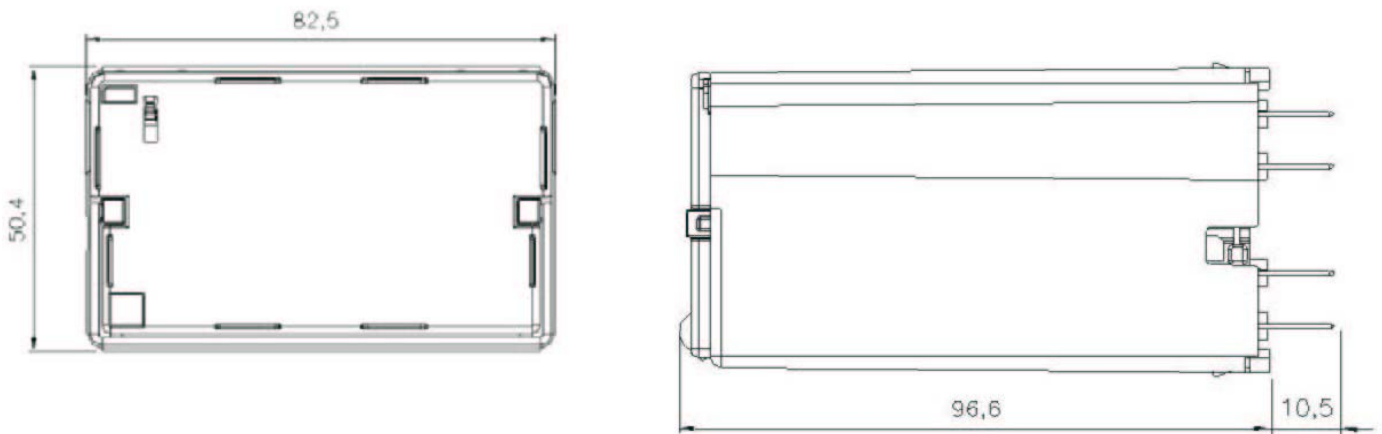

9.3 Sockets

	RAT2002		RAT3044, RAT3008	
	Screw	Double Faston	Screw	Double Faston
Front connection	PAV2 IP 10	PAV2-2C IP 10	PAV3 IP 10	PAV3-2C IP 10
Rear connection	PAR2 OP	PAR2-2C OP	PAR3 OP	-

PAV2 IP10 & PAV2-2C IP10

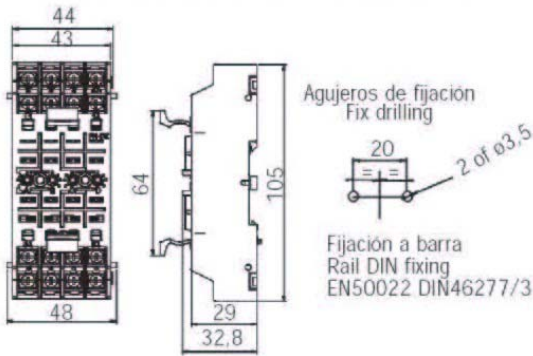

PAV3 IP10 & PAV3-2C IP10

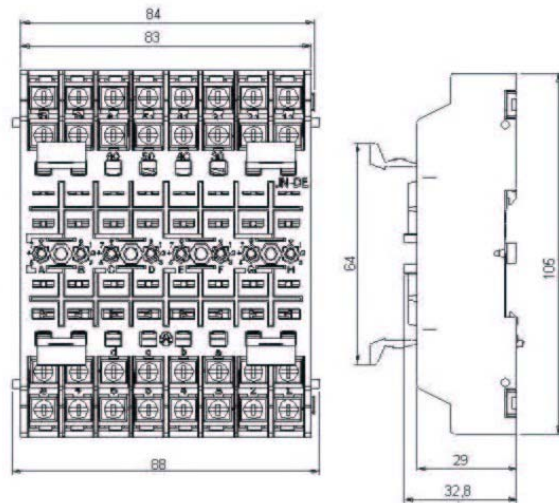

PAR2 OP & PAR2-2C OP

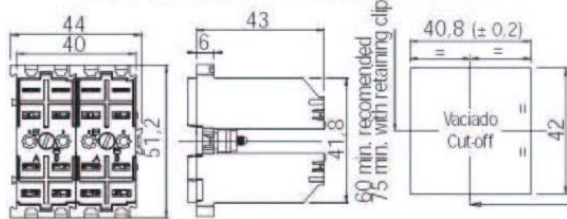

PAR3 OP

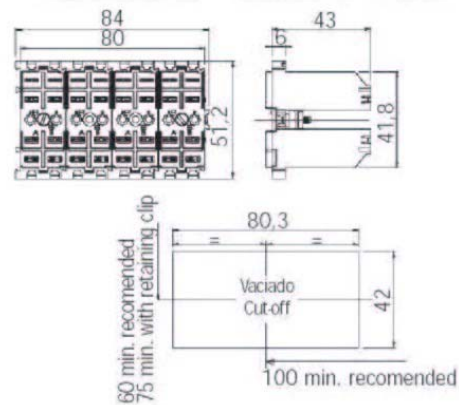

Minimum torque value: 0.5 Nm
Maximum torque value: 1 Nm

10 APPENDIX 1. MODEL SELECTION TABLE

RANGE AND SELECTION TABLE						
Model	Contact type	Voltage Vdc · Vac	OP	X	X	0
RAT2002	2 timer contacts					
RAT3008	8 timer contacts					
RAT3044	4 timer + 4 instantaneous					
OPTIONS						
High breaking capacity		NO		0		
		YES		1		
Dependent control voltage					0	
Independent control voltage		24 Vdc			1	
		48 Vdc			2	
		72 Vdc			3	
		60 Vdc			4	
		96 Vdc			5	
		110 Vdc			6	
		125 Vdc			7	
220 Vdc			8			

Example: RAT2002-125 Vdc-OP000